

GOMCO®
MOBILE
CONSTANT AND INTERMITTENT
MODELS 6036 & 6037

www.ardusmedical.com

**Allied Healthcare
Products, Inc.**

GOMCO® Division

1720 Sublette Avenue

St. Louis, MO 63110 U.S.A.

Telephone: (314) 771-2400

Toll Free: (800) 444-3954

INSTRUMENTS OF CARE®

© Allied Healthcare Products, Inc. 1993

**OPERATION, MAINTENANCE
AND
SERVICE MANUAL**

INDEX

- 1.0 General Information
- 2.0 Specifications
- 3.0 Set-Up
- 4.0 Operating Procedure
- 5.0 Operating Principle
- 6.0 Maintenance and Service
- 7.0 Illustrations
- 8.0 Trouble Shooting
- 9.0 Replacement Parts List
- 10.0 Warranty
- 11.0 Copyright

1.0 GENERAL INFORMATION:

1.1 Purpose:

The Gomco Models 6036 and 6037 Constant and Intermittent pumps are designed to provide two types of vacuum service. Constant suction provides vacuum levels fully adjustable from 0 to 200 mm of mercury with a maximum air flow of 25 liters per minute. For applications that require mild intermittent suction, the pump will provide 0 to 200 mm of mercury with a maximum air flow of 4 liters per minute. While using intermittent suction, the user can adjust the amount of time the vacuum is to be applied (1 to 90 seconds). The amount of time the unit vents to atmosphere is 12 seconds.

1.2 Features, Model 6036:

Supplied with Model 6036 as standard equipment are:

1. One (1) 600 ml glass collection bottle (used on constant).
2. One (1) 2800 ml glass collection bottle with overflow protection cap assembly (used on intermittent).
3. Two (2) disposable tubing packages, each containing a 15-inch and a 72-inch length of clean 1/4 inch I.D. clear flexible PVC tubing.
4. Two (2) packages, of 3 each, of bacteria filters.
5. Compact cart with non-marking casters, easy to clean stainless steel top work surface, illuminated on-off switch, lamps to indicate constant or intermittent service, "on" time control, vacuum gauge, vacuum regulator and hospital grade plug.

1.2.1 2800 ml Bottle Assembly:

Your Gomco Pump has an overflow protection device called the Cap and Float Assembly. When collected patient drainage fluids reach the last graduation of your collection bottle, the vacuum supply to the collection bottle is shut off by the cap and float assembly.

1.3 Features, Model 6037

Supplied with Model 6037 as standard equipment are:

1. One (1) 1100 ml disposable collection container with overflow protection cap (used on constant).
2. One (1) 2100 ml disposable collection container with overflow protection cap (used on intermittent).
3. Two (2) disposable tubing packages, each containing a 15-inch and a 72-inch length of clean 1/4 inch I.D. clear flexible PVC tubing.
4. Two (2) packages, of 3 each, of the bacterial filters.
5. Compact cart with non-marking casters, easy to clean stainless steel top work surface, illuminated on-off switch, lamps to indicate constant or intermittent service, "on" time control, vacuum gauge, vacuum regulator and hospital grade plug.

1.4 Bacterial Filter:

The high efficiency bacterial filter is common to both the 6036 and 6037 units. The filter is custom engineered to prevent fluid and aerosol contamination of mobile suction units. This filter features a hydrophobic, micro-porous membrane which filters air with maximum efficiency (0.3 micron particles in air), while blocking the flow of aqueous fluids and aerosol contaminants. The Gomco high efficiency filter protects against suction pumps contamination in the case of canister overflow as it helps prevent the overflow from reaching the pump.

2.0 SPECIFICATIONS:

NOTE: Specifications are nominal and subject to change without prior notice.

- 2.1 **VACUUM RANGE:**
0 to 200 mm Hg.
- 2.2 **FLOW RATE (Open):**
Constant - 20 lpm
Intermittent - 4 lpm
- 2.3 **ELECTRICAL REQUIREMENTS:**
115 volts 60 Hz (2.0 amps)
(A 230 volt unit is also available)
- 2.4 **MOTOR AND PUMP DESCRIPTION:**
4 pole, permanent split capacitor motor, direct drive diaphragm pump.
 - 2.4.1 **PUMP (Only):**
Vacuum - 22 inch Hg. Minimum
Flow - 28 lpm
- 2.5 **DIMENSIONS:**
(H) 33 in. X (D) 17 in. X (W) 23 in.
- 2.6 **WEIGHT:**
Shipping - 78 Pounds
Net - 62 Pounds
- 2.7 **DUTY:**
Continuous: 24 hours

10.0 WARRANTY:

The seller warrants that the products manufactured by the seller are free from defects in material and workmanship for a period of one year.

11.0 COPYRIGHT:

The drawings and specifications that appear in this manual shall not be reproduced, copied, or used as the basis for the manufacture of this apparatus. Copyright is limited to the U.S. Government for the use in military service, training programs and other technical publications.

3.0 SET-UP:

3.1 BACTERIA FILTERS:

Install two bacteria filters to the stand prior to patient applications as follows.

1. Locate the vacuum and filter connection on the bottom of the stand body, (See figure 1).
2. Screw the threaded ends of the filter into the vacuum filter connections by turning in a clockwise direction.
3. Tighten finger tight.

CAUTION: Care must be taken when installing the filter to prevent thread damage due to cross threading and over tightening.

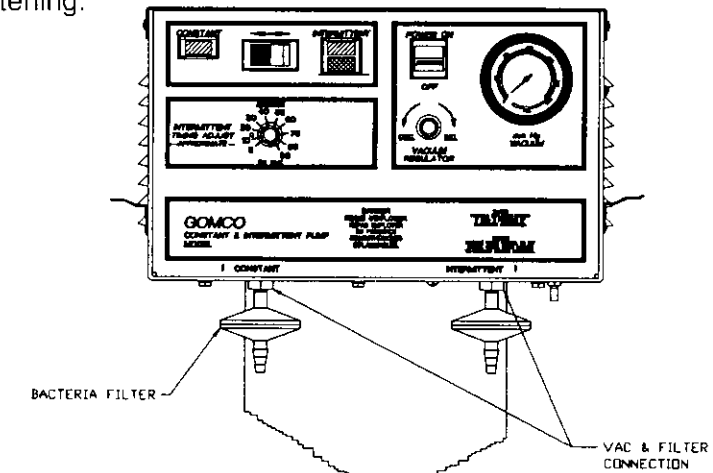

3.2 600 ml Collection Bottle: (See Illustration No. 5)

FIGURE 1

1. The bottle and cap assembly should be sterilized prior to use (See 6.4).
2. The bottle should be assembled as shown in Illustration No. 5.
3. Insert the bottle assembly into the wire bottle bracket located on the base of the stand.
4. Connect the 15-inch length of tubing, enclosed in the tubing package, to the "short" metal bottle tube and to the bacteria filter located under the word "CONSTANT".
5. Connect the 72-inch length of patient tubing, enclosed in the tubing package, to the "long" metal bottle tube.

3.3 2800 ml Collection Bottle: (See Illustration No. 6)

1. The bottle and cap assembly should be sterilized prior to use (see 6.4).
2. The bottle should be assembled as shown in Illustration No. 6.
3. Insert the bottle assembly into the wire bottle bracket located on the base of the stand.
4. Connect the 15-inch length of tubing, enclosed in the tubing package, to the vertical fitting on the bottle cap and float assembly marked "to pump" and to the bacteria filter located under the word "INTERMITTENT".
5. Connect the 72-inch length of patient tubing to the long bent metal tube of the cap assembly.

3.4 1100 ml Disposable Collection Container - Single Patient Use: (See Illustration No. 5A)

1. Make sure the filter shut-off is in place in the underside of the lid.
2. Place the bottle on a flat surface and snap the lid on firmly.
3. Connect the 72-inch length of patient tubing, enclosed in the tubing package, to the 90° tubing connector in the lid marked "patient".
4. Connect the 15-inch length of tubing to the vertical connector on the lid marked "vacuum".
5. Connect the other end of the 15-inch tubing to the barbed end of the bacteria filter beneath the word "CONSTANT".
6. Install the container in the appropriate wire bracket located on the stand base.

3.5 **2100 ml Disposable Collection Container - Single Patient Use:**

(See Illustration No. 6A)

1. Make sure the filter shut-off is in place in the underside of the lid.
2. Place the bottle on a flat surface and snap the lid on firmly.
3. Connect the 72-inch length of patient tubing, enclosed in the tubing package, to the 90° tubing connector in the lid marked "patient".
4. Connect the 15-inch length of tubing to the vertical connector on the lid marked "vacuum".
5. Connect the other end of the 15-inch tubing to the barbed end of the bacteria filter beneath the word "INTERMITTENT".
6. Install the container in the appropriate wire bracket located on the stand base.

4.0 **OPERATING PROCEDURE:**

(See Illustration No. 3)

1. The "On-Off" switch should be in the "Off" position.
2. Plug the line cord into a grounded electrical outlet, making sure that is is the same voltage as indicated on the unit nameplate. The receptacle should be marked "Hospital Grade" to insure grounding.
3. Be sure the length of the tubing from the bottle to the bacteria filter is dry.
4. Push the "On-Off" in the front control panel to the "On" position.
5. Select the type of vacuum service. Push the selector switch to the left for constant suction or to the right for intermittent suction. The white lamps will indicate the selected service.
6. Set the desired vacuum level by pinching off the patient tubing and turning the vacuum regulator knob clockwise to increase and counterclockwise to decrease. The container on the left side is used for constant suction and the container on the right side is used for intermittent suction.
7. If the intermittent suction is chosen the timing must be set.
 - a. To adjust the "On" time (applied suction), turn the adjustment knob on the front panel to the desired time in seconds.

NOTE: The time selected should be long enough to all the unit to reach the vacuum level set in step 6.
 - b. The "Off" time (vented to atmosphere) is factory set and needs no adjustment. The red lamp in the front panel indicates the system is venting.
8. Your pump is now ready for patient use.

5.0 **OPERATING PRINCIPLE:**

The negative and positive pressures of a diaphragm pump are developed by the reciprocating motion of the diaphragm inside the pump head. The pressures are maintained by the motion of the diaphragm and the pressure and suction flapper valves. On the up stroke, the pressure valve will open to allow air flow through the exhaust or pressure port. On the down stroke, the pressure valve closes and the suction valve opens, which draws a vacuum or creates a negative pressure at the suction side.

6.0 **MAINTENANCE AND SERVICE:**

6.1 **Pump Lubrication:**

The pump and motor are permanently lubricated and require no oiling or greasing. Do Not at any time lubricate any of the parts with oil, grease or petroleum products.

6.2 **Pump Maintenance:**

6.2.1 The air filters and gasket should be checked or replaced at a minimum of at least once a year (See Illustration No. 4).

6.2.2 **To Replace Air Filters and Gasket**

(Included in Parts Kit 01-90-2526, Two Kits Required)

1. Remove the four (4) phillips head screws from the top cover of the pump. The filter The filters and gasket are located beneath this top cover (See Illustration No. 4).

NOTE: There are two heads on this pump. Both heads are maintained the same and should be cleaned or replaced at the same time.
2. Remove the gasket and filters and replace the filters with new ones.
3. The gasket may be cleaned with water, but should be replaced yearly.

ILLUSTRATION NUMBER

01-90-2771	2800 ml Collection Bottle Assembly	6
	2800 ml Glass Bottle	6
	Cap and Float Assembly	6
01-90-2768	Cap and Float Assembly	6
	Cap (Including Gasket)	6
	Cap Gasket	6
	Float Gasket	6
	Float Assembly	6
01-90-3620	Elbow with Orifice	
	Relief Valve	01-90-3646
	Elbow Assembly	01-90-3647
	Miscellaneous Parts Numbers	
	Bottle Bracket	01-90-5147
	Bracket DCU	01-90-5146
	1100 ml Disposable Collection Container 12/Case	01-90-3695
	1100 ml Disposable Collection Container 48/Case	01-90-3696
	2100 ml Disposable Collection Container 10/Case	01-90-3712
	2100 ml Disposable Collection Container 42/Case	01-90-3711
	Filter (Package of 3)	01-90-3100
	Diaphragm Pump Assembly	01-90-5093
	Solenoid Timer	01-90-3897
	Muffler	01-90-3060
	Muffler Cap	01-90-3136
	Motor Mount	01-90-2599
	Brass Elbow (1/4 NPT)	01-90-2469
	Terminal Block	01-90-3609
	Solenoid Valve	01-90-2356
	Elbow with Orifice	01-90-3620
	Fan 115V	01-90-2817
	Power Cord Assembly	01-90-2737
	Bacteria Filter (3/Package)	01-90-3100
	Tubing Package (15" & 72" Piece)	01-90-2000
	Repair Kit (Pump) (Two Required)	01-90-2526
	Plastic Tee	01-90-2591
	Silicone Rubber Tubing (6 Foot)	01-90-9044

9.0 REPLACEMENT PARTS LIST FOR MODELS 6036 AND 6037:

		ILLUSTRATION NUMBER	
01-90-5048	Stand Assembly	2	
Body	01-90-2826	2	
Handle	01-90-2271	2	
Handle Spacer	01-90-2270	2	
Devilbiss Hook	01-90-2742	2	
Vacuum Connections	01-90-2765	2	
Upright Assembly	01-90-2738	2	
Base Assembly	01-90-5435	2	
Caster, Non-Locking	01-90-3879	2	
Caster, Locking	01-90-3880	2	
Foam, Bottom	01-90-5409	2	
Foam, Sides	01-90-3434	2	
01-90-2738	Upright Assembly	2	
Upright	01-90-2572	2	
Cord Clip	01-90-1294	2	
01-90-5435	Base Assembly	2	
Base	01-90-2739	2	
Caster Socket	01-90-2908	2	
Rubber Bumper	01-90-2816	2	
Pad (2800 ml) Bottle	01-90-2001	2	
Pad (600 ml) Bottle	01-90-5111	2	
Pad for DCU	01-90-2538	2	
01-90-3631	Stainless Steel Top Assembly	1	
Stainless Steel Top	01-90-2573	1	
Foam (Top)	01-90-3435	1	
01-90-5469	Front Panel Assembly	3	
Front Panel	01-90-3904	3	
On-Off Switch	01-90-2304	3	
Selector Switch	01-90-3590	3	
Constant Lamp	01-90-3588	3	
Intermittent Lamp	01-90-3589	3	
Vacuum Gauge	01-90-3544	3	
Vacuum Regulator	01-90-3592	3	
Knob	01-90-2351	3	
Potentiometer	01-90-3603	3	
01-90-3592	Vacuum Regulator	3	
Regulator Base	01-90-3615	3	
Regulator Top	01-90-3616	3	
Rubber Diaphragm	01-90-3617	3	
Brass Elbow (1/8 NPT)	01-90-3480	3	
Hex Mounting Nut	01-90-3591	3	
01-90-2454	600 ml Collection Bottle Assembly	5	
600 ml Glass Bottle	01-90-2675	5	
Cap Assembly	01-90-2453	5	
01-90-2453	Cap Assembly	5	
Rubber Bottle Cap	01-90-2674	5	
Short Tube	01-90-2691	5	
Long Tube	01-90-2692	5	

6.2.3 To Replace Valves (Included in Parts Kit 01-90-2526, Two Kits Required)

1. Remove the four (4) socket head machine screws holding the pump head in place.

NOTE: Some pump heads may be shimmed. When removing the head, take note of their location for proper replacement.

2. Remove the slotted machine screw that holds each valve in place.
3. The stainless steel inlet and outlet valves are interchangeable. Place the inlet valve in position against the retainer bar, replace the valve holder over the valve and secure with the machine screw. Position the valve holder so that the "X" is located in the lower right hand corner toward the inlet of the air chamber.
4. Place the outlet valve against the retainer bar; replace the valve retainer over the valve and secure with the machine screw.
5. Replace the head and tighten the socket head screws to 90 - 100 inch pounds.

6.2.4 To Replace Diaphragm:

1. Remove the four (4) socket head machine screws holding the pump head in place.

NOTE: Some pump heads may be shimmed. When removing the head, take note of the location for proper replacement.

2. Remove the two (2) phillips head machine screws from the diaphragm retainer plate. Remove the plate and diaphragm.
3. The new diaphragm will fit in any position on the connecting rod.
4. Replace the retainer plate and the two (2) phillips head machine screws. Torque to 30 inch pounds.

CAUTION: Do not raise any burrs or nicks on the heads of these screws. These burrs could cause damage to the inlet valve.

CAUTION: Do not at any time attempt to remove the connecting rod or completely disassemble the pump. If it does not give you the proper service after installing a new Service Kit, Part No. 01-90-2526, please return it to the factory for repair.

6.3 Bacteria Filter:

The bacteria filter should be replaced after one (1) month of patient use or when a reduction of the air flow rate is noticed. **It must be replaced** in the event fluids have entered in as in collection bottle overflow.

1. Unscrew the filter from the vacuum and filter connection (See Illustration No. 1) by hand turning in a counterclockwise direction.
2. Screw a new filter into the vacuum and filter connection by turning in a clockwise direction finger tight.

CAUTION: Care must be taken when replacing the filter to prevent thread damage due to cross threading and over tightening.

6.4 Glass Collection Bottle and Cap Assembly Sterilization:

1. Remove the cap assembly from the bottle.
2. Dispose of drainage fluids and materials in the bottle.

WARNING: The drainage fluids are a biochemical hazard and must be disposed of in accordance with the local and state codes for disposing of biochemical hazardous material.

3. Soak the bottle and cap assembly in a warm detergent solution. Wash all the parts with a nylon bristle brush, rinse thoroughly with water and aerate.
4. Autoclave at 250° F for 15 minutes following the autoclave manufacturer's recommended procedure.

CAUTION: Do not flash autoclave the glass collection bottle. If desired, sterilize with Ethylene Oxide Gas. Follow manufacturer's directions for recommended procedure.

6.5 Disposable Collection Containers. 1100 ml and 2100 ml:

WARNING: When these containers are contaminated with drainage fluids, they are a biochemical hazard and must be disposed of in accordance with local and state codes for disposing of biochemical hazardous material.

6.6 Solenoid Valve Replacement:

In the event that solenoid Valve No. 2 (venting solenoid) must be replaced, take note that the brass elbow in the top "EXH" port of the solenoid has an orifice. This elbow must be screwed into the top "EXH" port of the replacement solenoid valve for the vacuum system to function properly.

6.7 Vacuum Regulator:

To replace the rubber diaphragm assembly:

1. Remove the adjustment knob from the regulator stem.
2. Remove the stainless steel top cover from the stand.
3. Disconnect the two (2) white rubber tubes from the regulator body.
4. Remove the hex nut fastening the regulator to the front panel and remove the regulator from the stand.
5. Remove the four (4) machine screws fastening the regulator top to the regulator body and separate the two parts. The diaphragm assembly will slip out of the regulator top.
6. Prior to installing the new diaphragm assembly, be sure that the outside diameter of the rubber diaphragm is laying flat inside its plastic housing. Screwing the adjustment stem clockwise to bottom aids in maintaining its position.
7. Set the new diaphragm assembly onto the regulator body.
8. Slip the regulator top over the diaphragm assembly while aligning the screw holes.
9. Replace the four (4) machine screws and alternately tighten them.
10. Install the regulator into the stand.
11. Connect the two (2) white rubber tubes to the regulator body.
12. Replace the stainless steel top onto the stand.
13. Replace the adjustment knob onto the regulator stem.
14. Check for proper regulation.

CAUTION: The new diaphragm assembly is factory set for 200 mm Hg. Do not alter the adjustment screw.

9.0 TROUBLE SHOOTING

PROBLEM	PROBABLE CAUSE	REMEDY
PUMP WILL NOT RUN WHEN SWITCH IS PUSHED "ON"	<ol style="list-style-type: none"> 1. POWER SOURCE BAD OR INCORRECT VOLTAGE. 2. WIRING INCORRECT. 3. MOTOR BURNED OUT. 4. FAULTY SWITCH. 	<p>CHECK POWER OUTLET</p> <p>CHECK WIRING, SEE ILLUSTRATION NO. 8.</p> <p>REPLACE MOTOR/PUMP.</p> <p>REPLACE SWITCH.</p>
LOW SUCTION	<ol style="list-style-type: none"> 1. LOOSE BOTTLE CAP OR TUBING CONNECTION. 2. BACTERIA FILTER CLOGGED. 3. PUMP DIAPHRAGM TORN. 4. FAULTY SOLENOID VALVE. 5. WIRING INCORRECT TO VALVE. 	<p>CHECK ALL CONNECTIONS.</p> <p>REPLACE FILTER, SEE 6.3.</p> <p>REPLACE DIAPHRAGM, SEE 6.2.4.</p> <p>REPLACE SOLENOID, SEE 6.6.</p> <p>CHECK WIRING, SEE ILLUSTRATION NO. 8.</p>
NO TIMING ADJUSTMENT	<ol style="list-style-type: none"> 1. FAULTY POTENTIOMETER. 2. FAULTY TIMER. 	<p>REPLACE POTENTIOMETER.</p> <p>REPLACE TIMER.</p>

WARNING: All internal maintenance must be performed by qualified service personnel only.

7.0 ILLUSTRATIONS:

- Number 1 - Final Assembly, Model 6036
- Number 1A - Final Assembly, Model 6037
- Number 2 - Stand Assembly
- Number 3 - Front Panel Assembly
- Number 4 - Pump Assembly (Exploded) (Only One Head Shown)
- Number 5 - 600 ml Bottle Assembly
- Number 5A - 1100 ml Bottle Assembly
- Number 6 - 2800 ml Bottle Assembly
- Number 6A - 2100 ml Bottle Assembly
- Number 7 - Vacuum System Diagram
- Number 8 - Wiring Diagram

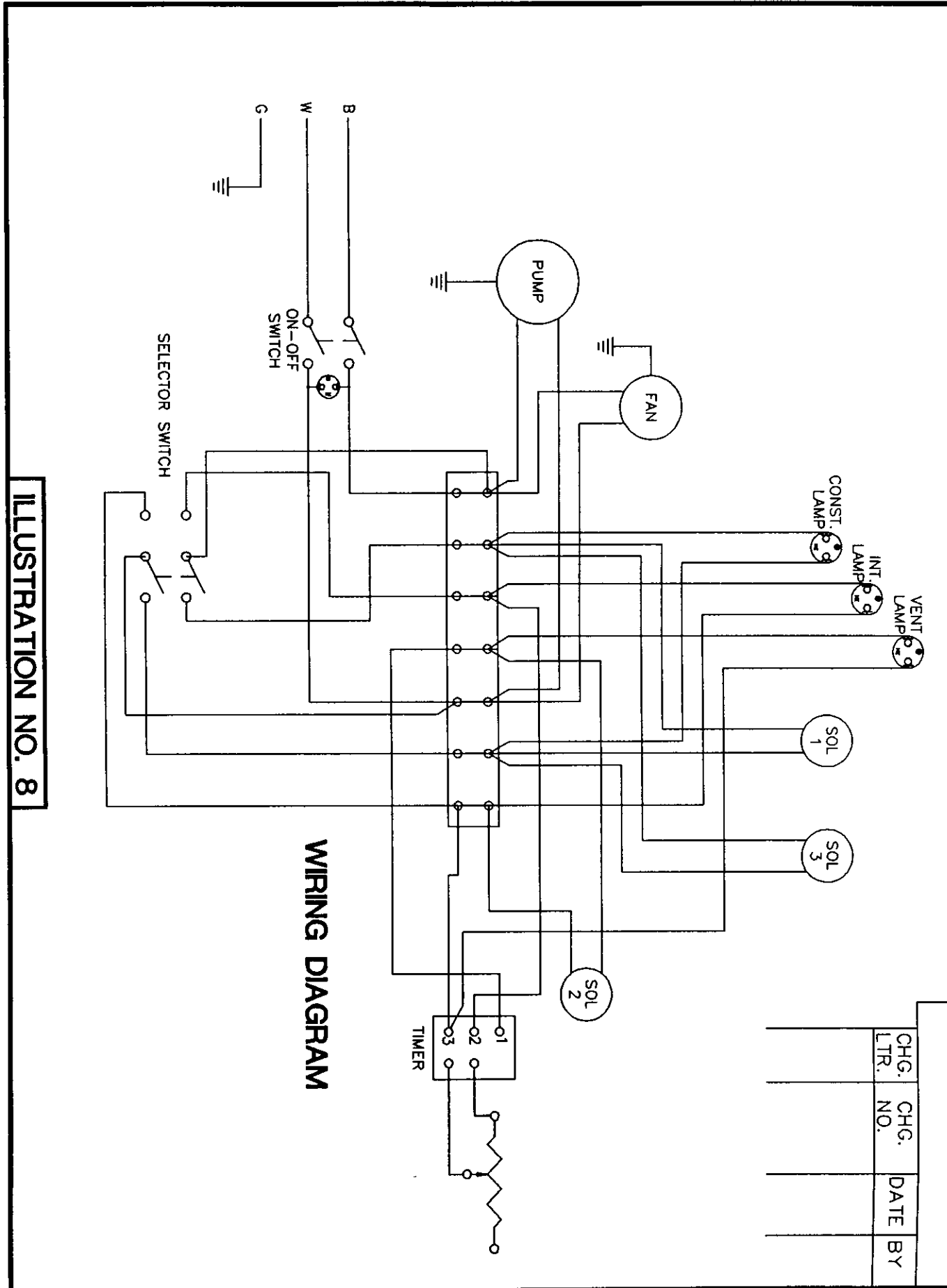
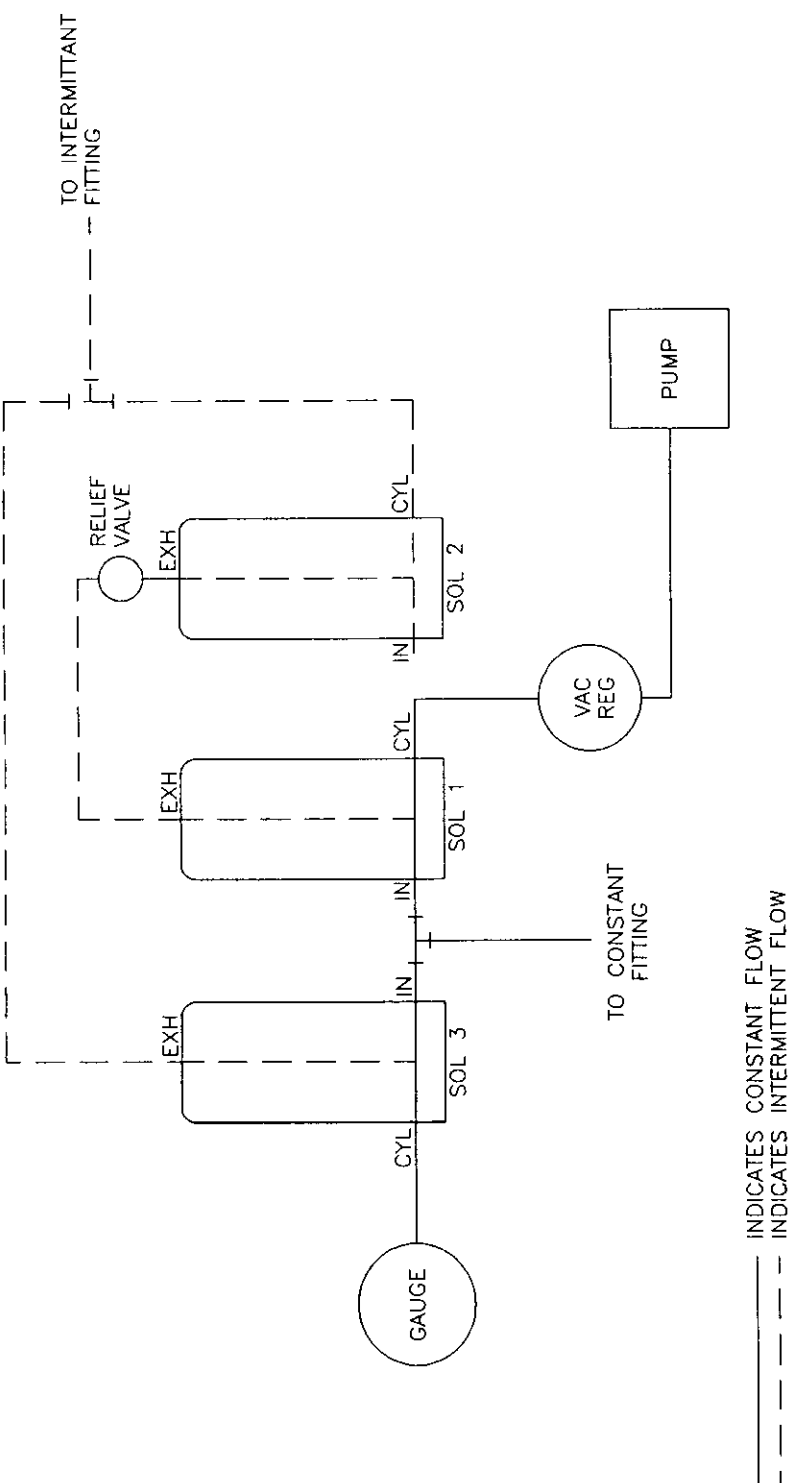

ILLUSTRATION NO. 7



CHG. LTR.	CHG. NO.	DATE	BY

BILL OF MATERIAL

ITEM	PART NO.	DESCRIPTION
1	01-90-2454	600 ml COLLECTION BOTTLE ASSY
2	01-90-5469	FRONT PANEL ASSY.
3	01-90-5093	DIAPHRAGM PUMP ASSY.
4	01-90-3609	TERMINAL BLOCK ASSY.
5	01-90-3631	STAINLESS STEEL TOP ASSY.
6	01-90-3100	BACTERIA FILTER/ PKG OF 3
7	01-90-5048	STAND ASSY.
8	01-90-2817	FAN 115V
9	01-90-2356	SOLENOID VALVE
10	01-90-2771	2800 ml COLLECTION BOTTLE ASSY
11	01-90-3897	TIMER
12	01-90-2737	POWER CORD
13	01-90-5147	BOTTLE BRACKET
14	01-90-5111	PAD, BOTTLE, 600 ml
15	01-90-2001	PAD, BOTTLE, 2800 ml
16		

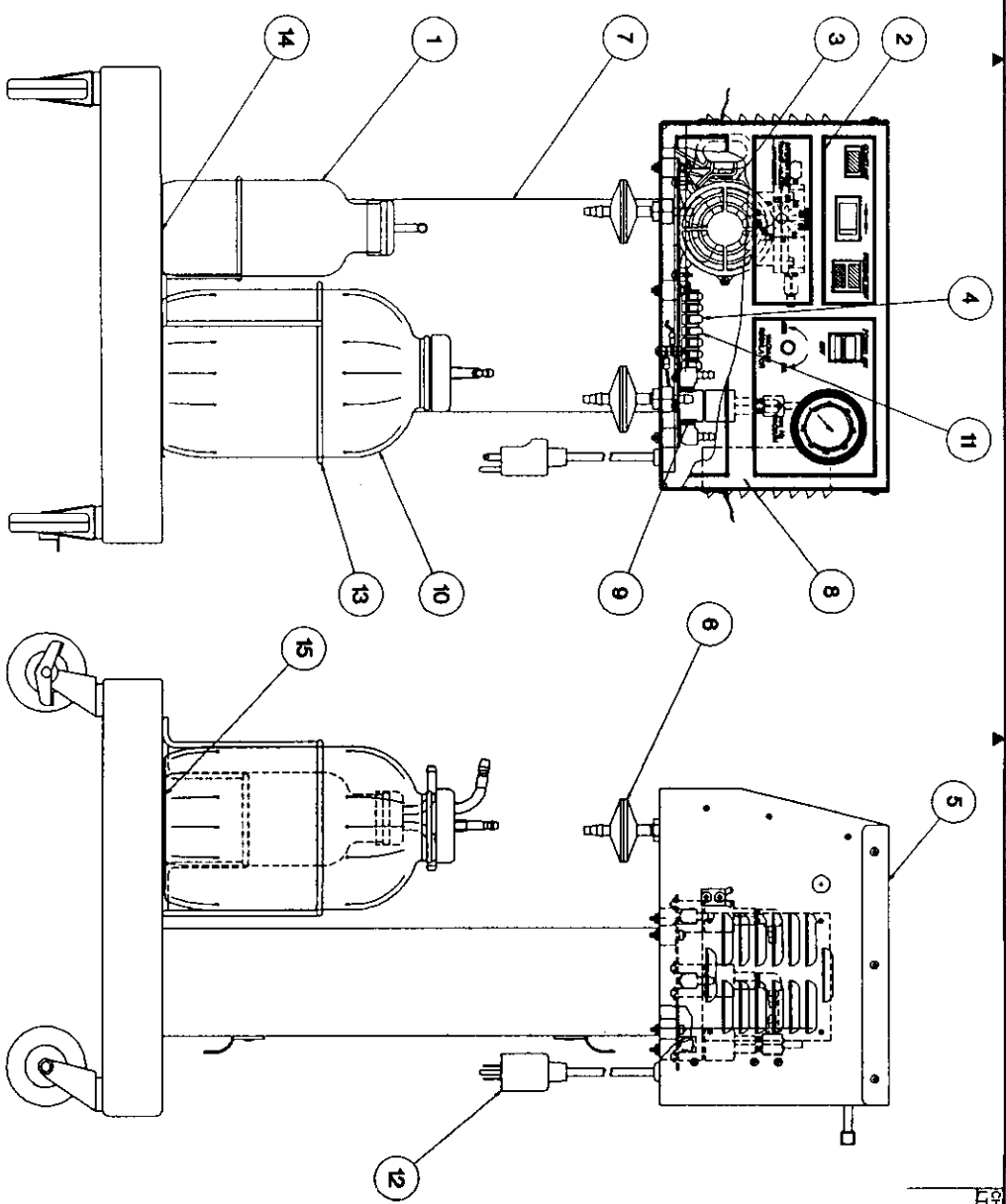

CHG. LTR.	CHG. NO.	DATE	BY

ILLUSTRATION 1

2100 ml Bottle

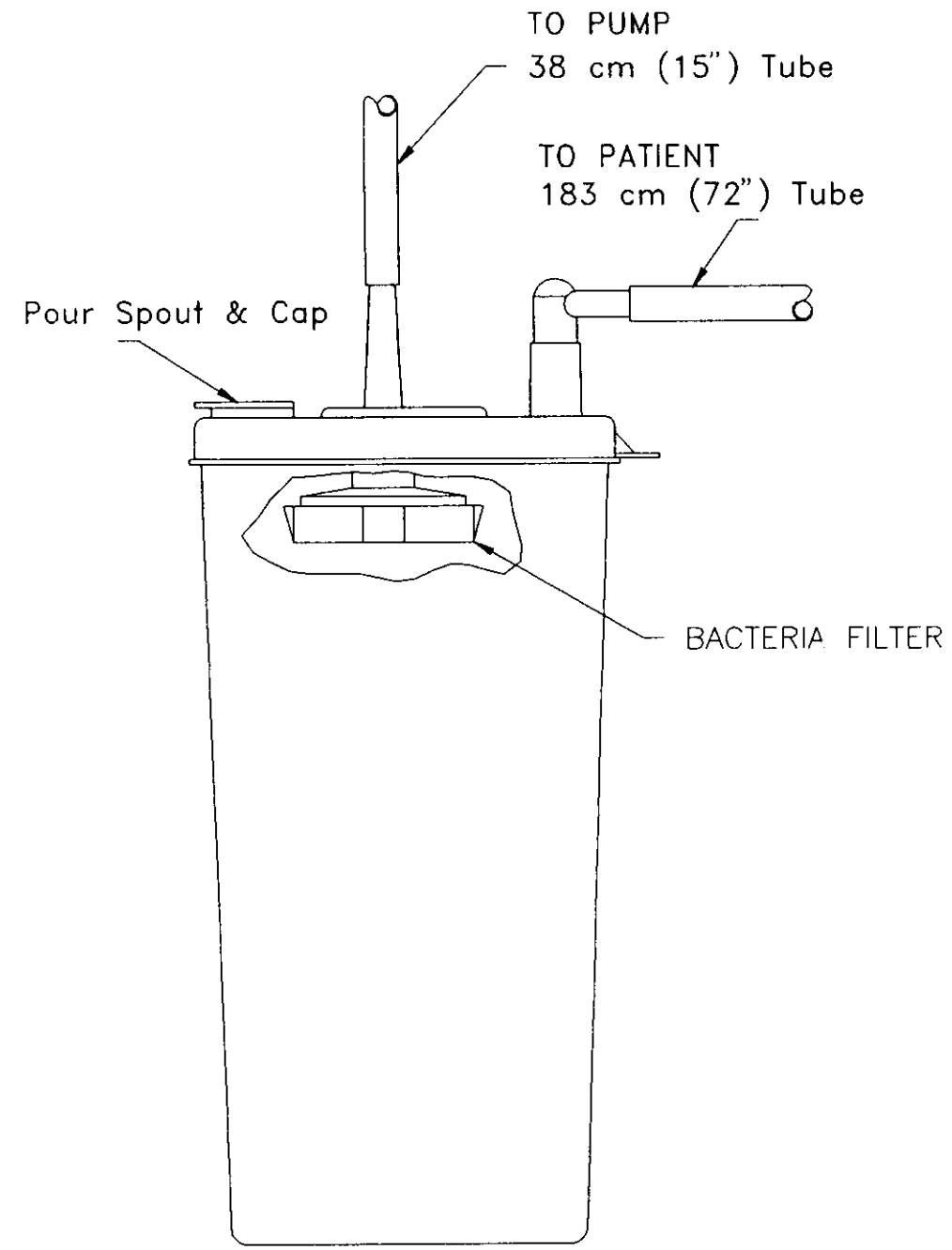

Case Part Nos.

01-90-3712 10/Case
01-90-3711 42/Case

ILLUSTRATION NO. 6A

ITEM	PART NO.	DESCRIPTION
1	01-90-3695	1100 ml DISPOSABLE BOTTLE 12/CASE
	01-90-3696	1100 ml DISPOSABLE BOTTLE 48/CASE
2	01-90-5469	FRONT PANEL ASSY.
3	01-90-5093	DIAPHRAGM PUMP ASSY.
4	01-90-3609	TERMINAL BLOCK ASSY.
5	01-90-3631	STAINLESS STEEL TOP ASSY.
6	01-90-3100	BACTERIA FILTER/ PKG OF 3
7	01-90-5048	STAND ASSY.
8	01-90-2817	FAN 115V
9	01-90-2356	SOLENOID VALVE
10	01-90-3711	2100 ml DCU 42/CASE
	01-90-3712	2100 ml DCU 10/CASE
11	01-90-3897	TIMER
12	01-90-2737	POWER CORD
13	01-90-5146	BOTTLE BRACKET
14	01-90-5111	PAD, BOTTLE, 600 ml
15	01-90-2538	PAD, BOTTLE, 2100 ml

CHG. CRG. DATE BY
LTR. NO.

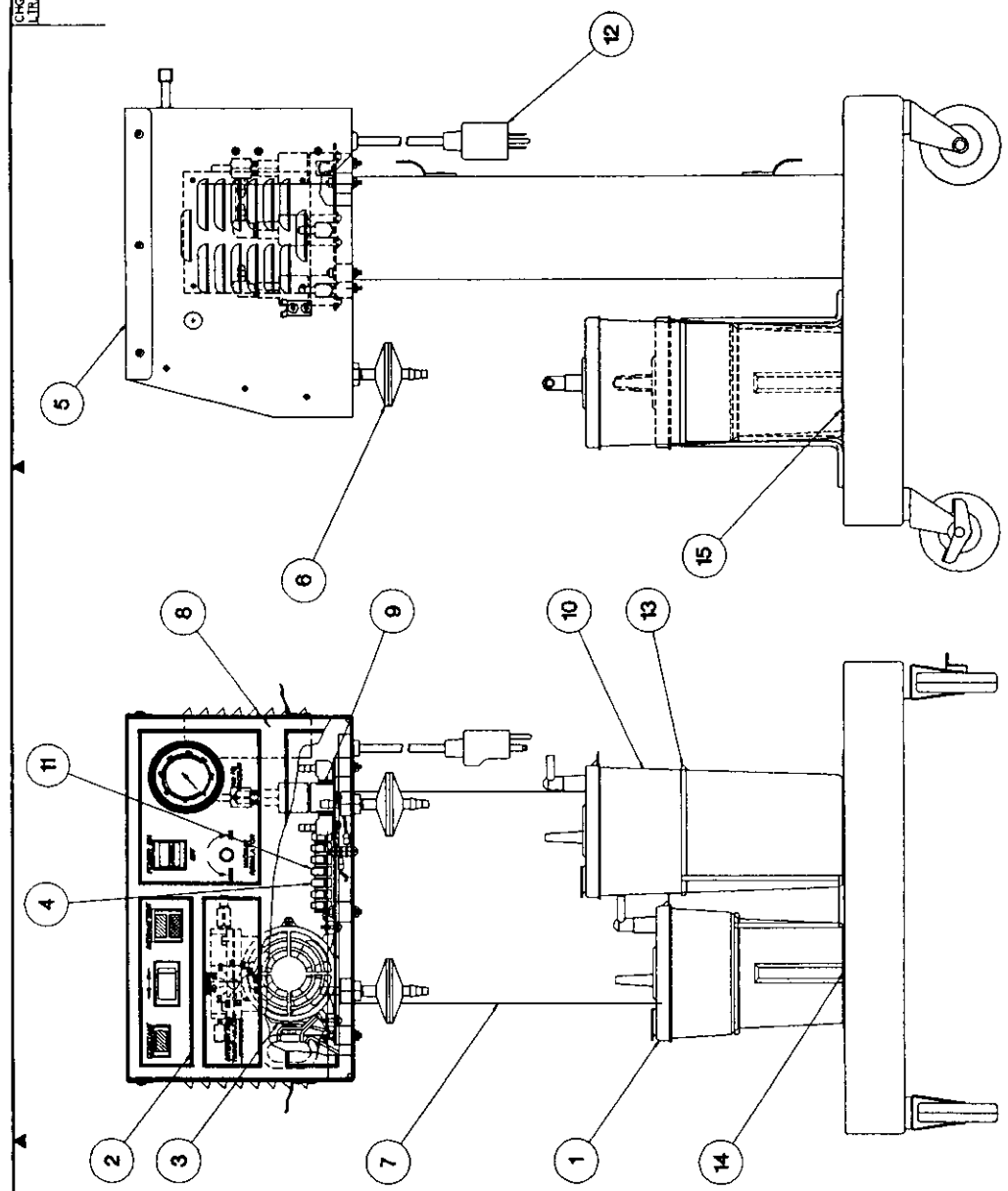
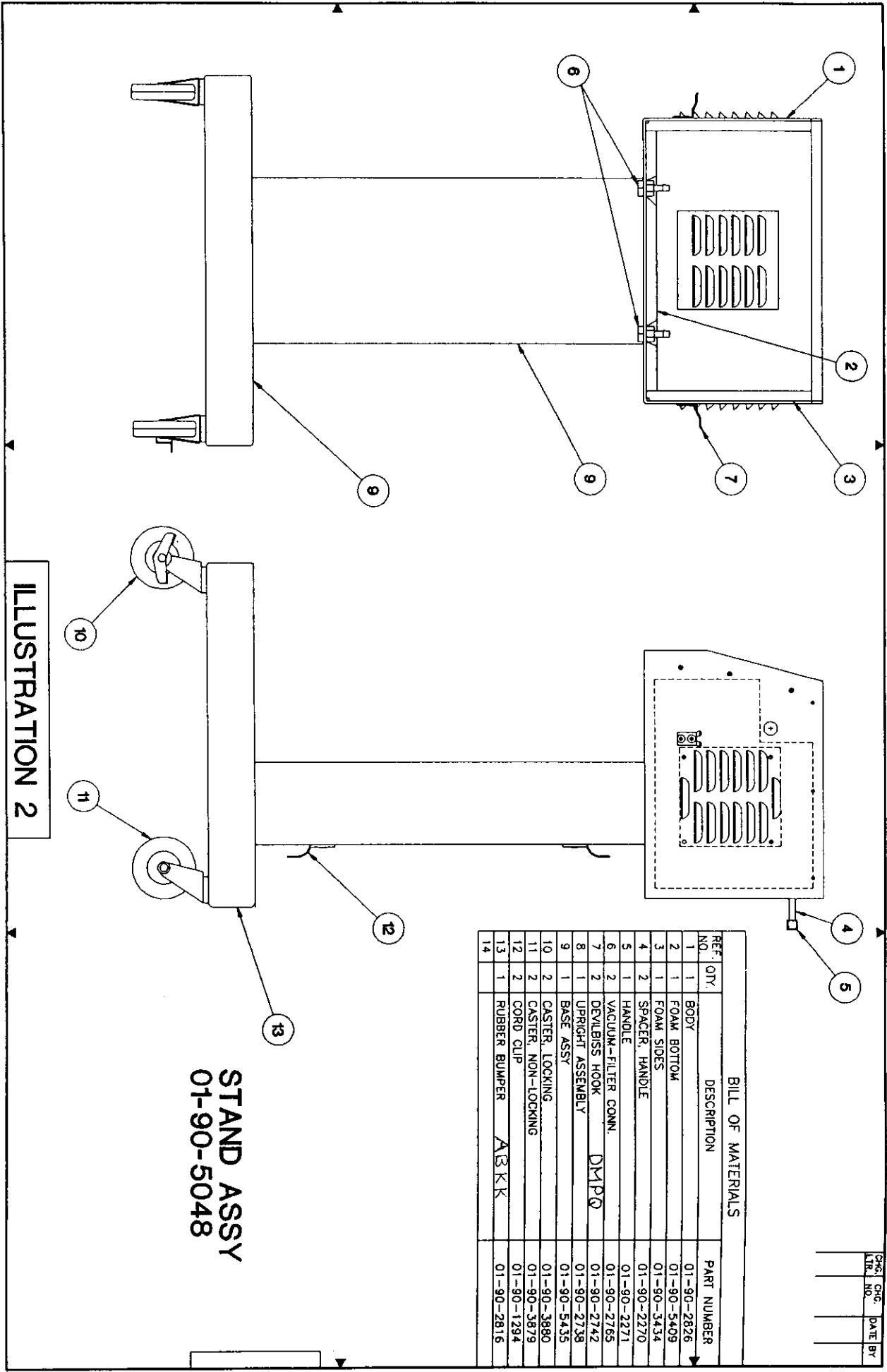

ILLUSTRATION 1A



STAND ASSY
01-90-5048

BILL OF MATERIALS

REF. QTY	DESCRIPTION	PART NUMBER
1	BODY	01-90-2826
2	FOAM BOTTOM	01-90-5409
3	FOAM SIDES	01-90-3434
4	SPACER, HANDLE	01-90-2270
5	HANDLE	01-90-2271
6	VACUUM-FILTER CONN.	01-90-2765
7	UPRIGHT ASSEMBLY	01-90-2742
8	DEVILBISS HOOK	DMPO
9	BASE ASSY	01-90-5435
10	CASTER, LOCKING	01-90-3880
11	CASTER, NON-LOCKING	01-90-3879
12	CORD CLIP	01-90-1294
13	RUBBER BUMPER	01-90-2816

ILLUSTRATION 2

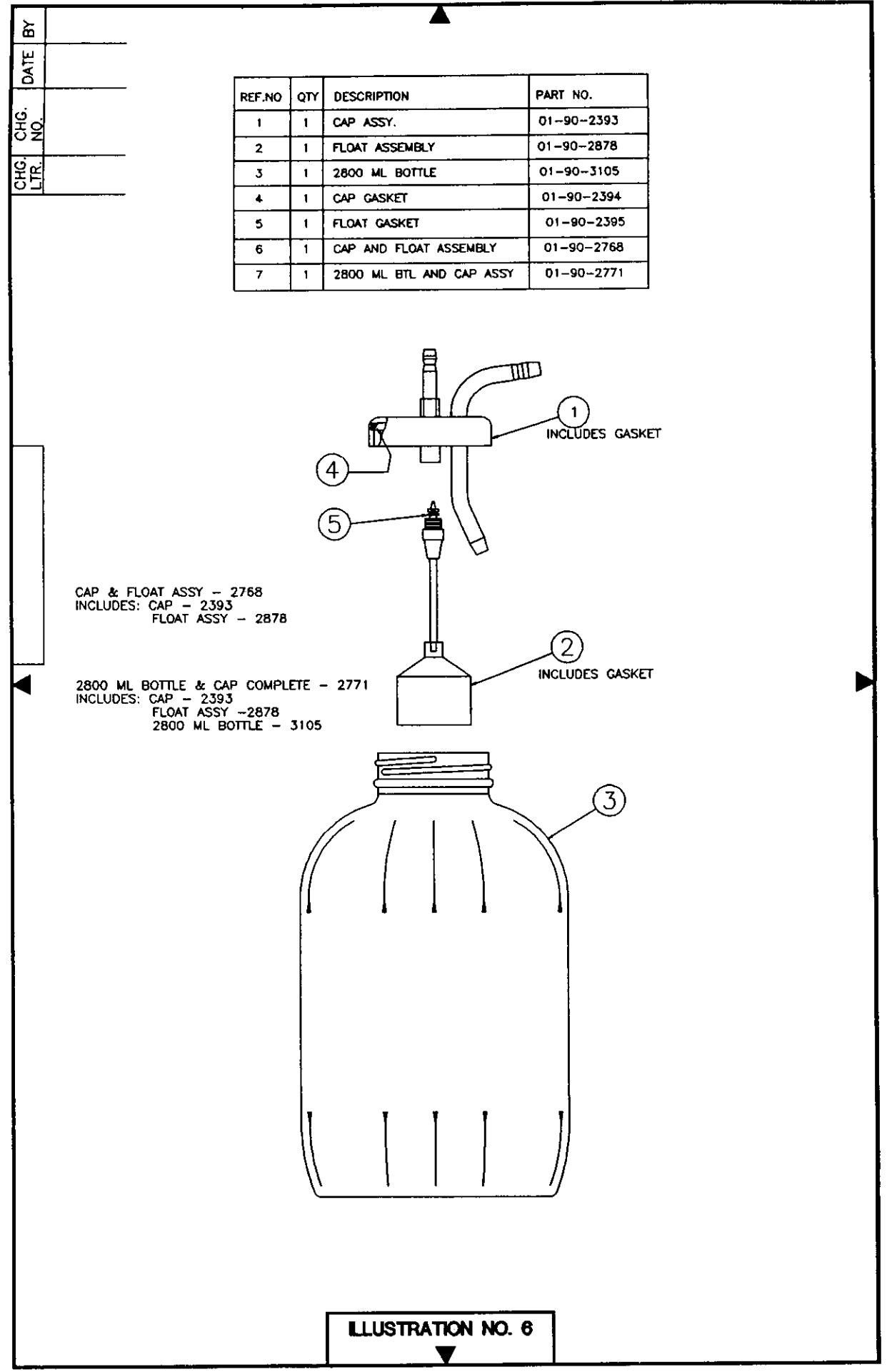

REF. NO	QTY	DESCRIPTION	PART NO.
1	1	CAP ASSY.	01-90-2393
2	1	FLOAT ASSEMBLY	01-90-2878
3	1	2800 ML BOTTLE	01-90-3105
4	1	CAP GASKET	01-90-2394
5	1	FLOAT GASKET	01-90-2395
6	1	CAP AND FLOAT ASSEMBLY	01-90-2768
7	1	2800 ML BTL AND CAP ASSY	01-90-2771

CAP & FLOAT ASSY - 2768
INCLUDES: CAP - 2393
FLOAT ASSY - 2878

2800 ML BOTTLE & CAP COMPLETE - 2771
INCLUDES: CAP - 2393
FLOAT ASSY - 2878
2800 ML BOTTLE - 3105

ILLUSTRATION NO. 6

CHG. LTR. NO. _____

CHG. NO. _____

DATE BY _____

ILLUSTRATION NO. 5A

**DISPOSABLE BOTTLE
SET-UP**

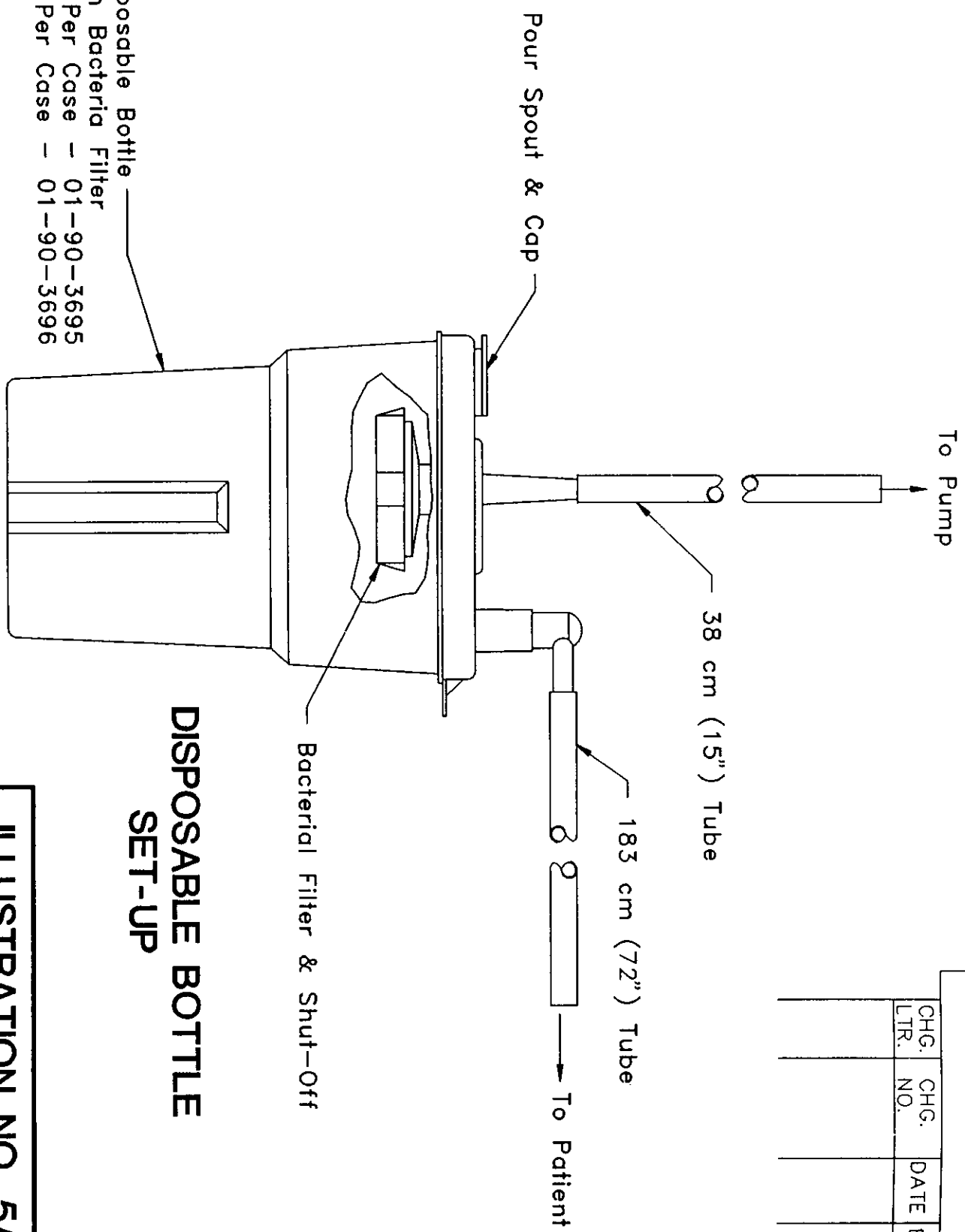

Disposable Bottle
With Bacteria Filter
12 Per Case - 01-90-3695
48 Per Case - 01-90-3696

CHG. LTR.	CHG. NO.	DATE	BY

ITEM NO.	PART NUMBER	DESCRIPTION
1	01-90-3904	FRONT PANEL
2	01-90-3588	CONSTANT LAMP
3	01-90-3580	SELECTOR SWITCH
4	01-90-3589	INTERMITTENT LAMP
5	01-90-3587	POT. ASSEMBLY 5 MEG
6	01-90-2304	ON-OFF SWITCH
7	01-90-3544	VACUUM GAUGE
8	01-90-2351	REGULATOR KNOB
9	01-90-3591	HEX MOUNTING NUT
10	01-90-3592	VACUUM REGULATOR ASSY
11		

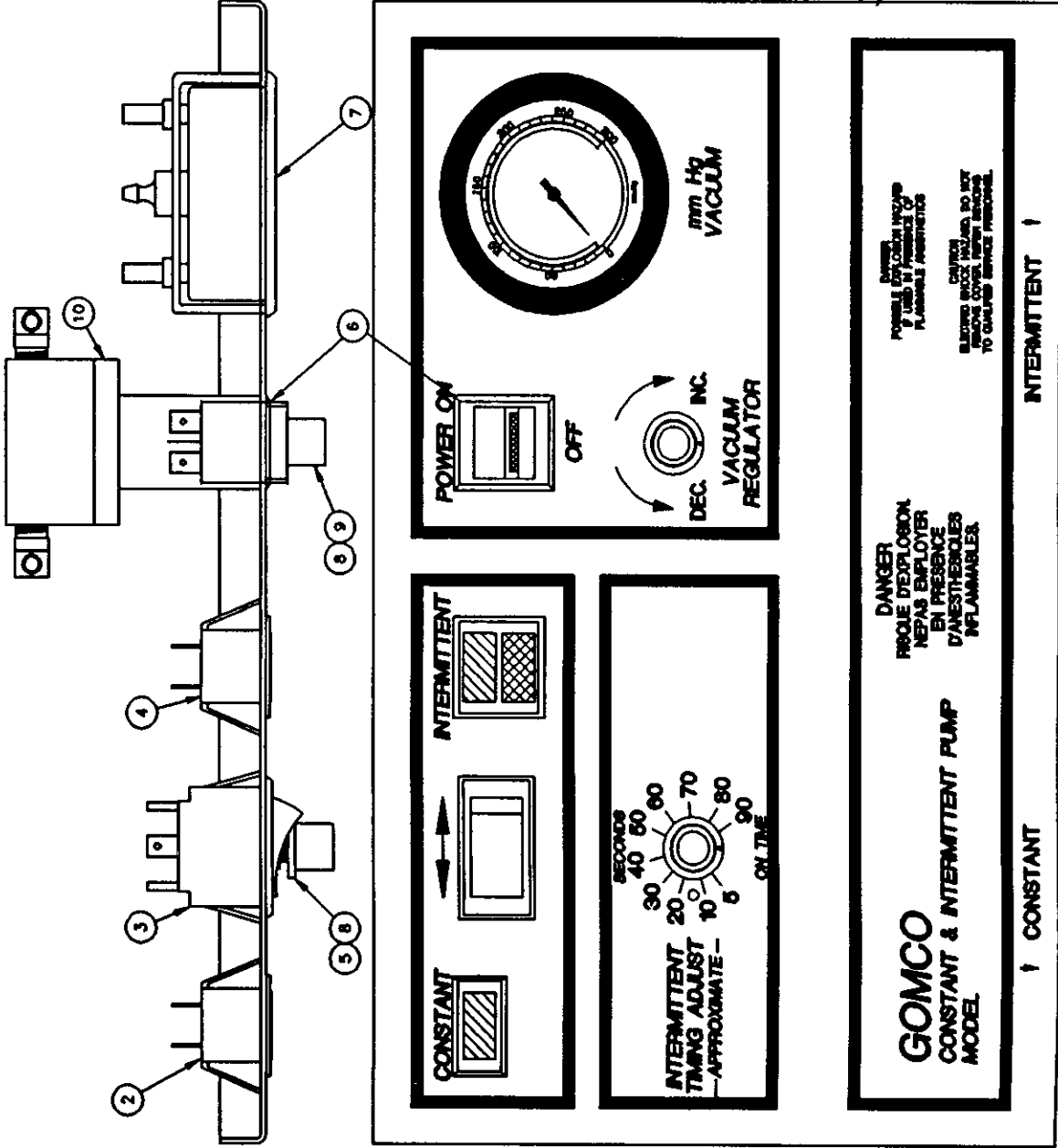
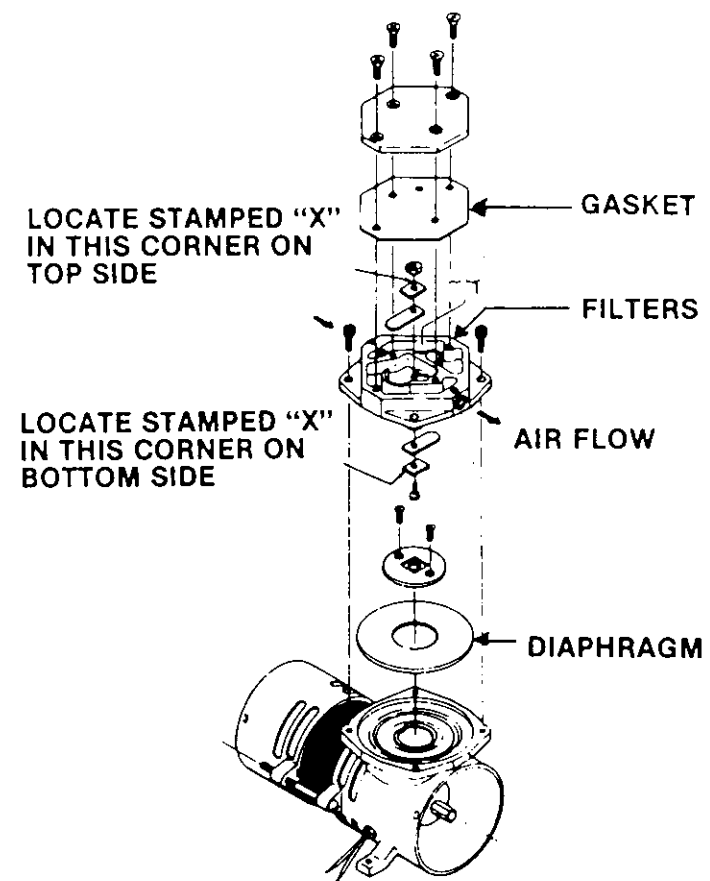
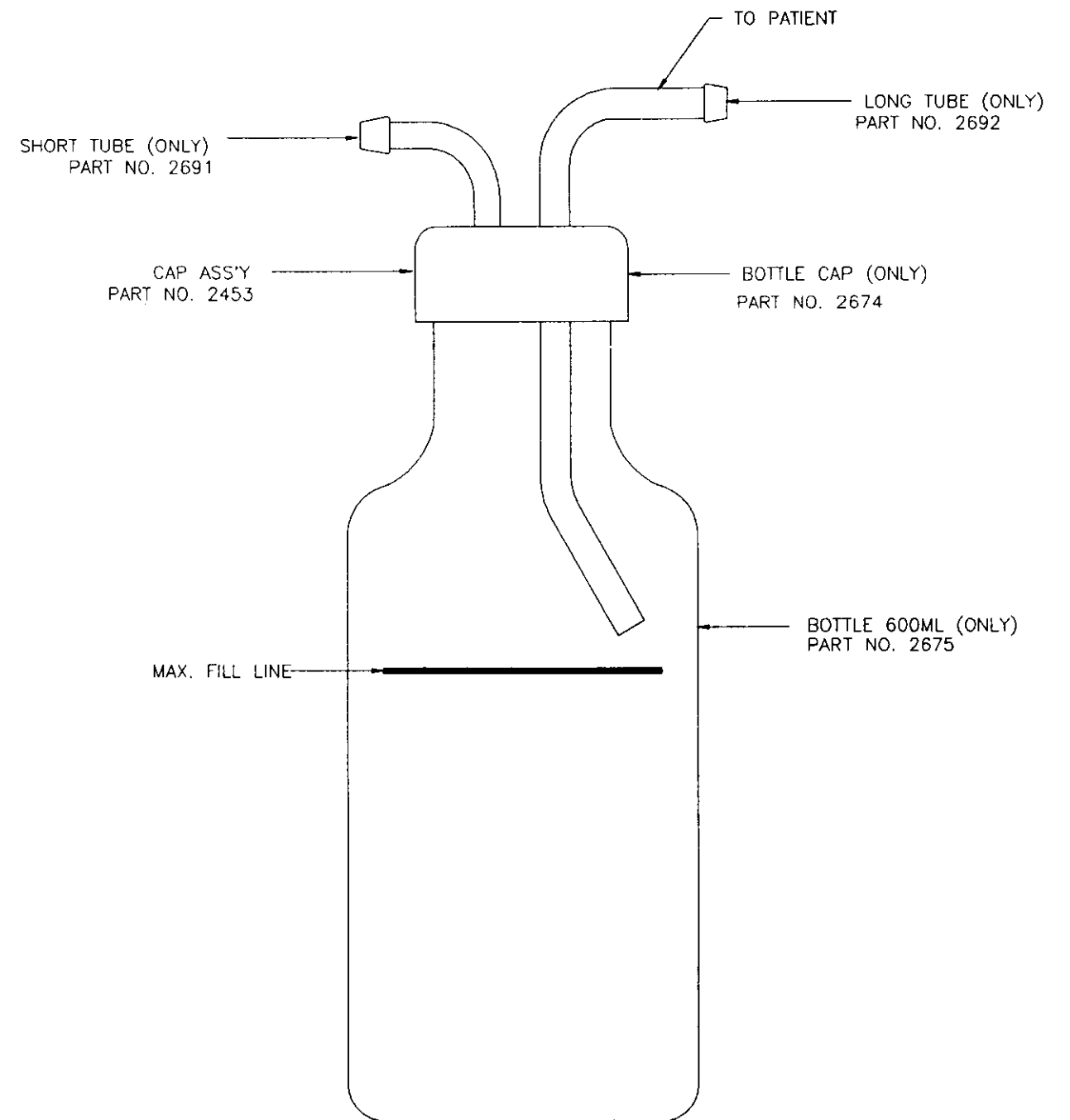

ILLUSTRATION 3



TWO (2) REPAIR KITS REQUIRED FOR DOUBLE-HEADED PUMP.

ILLUSTRATION NO. 4



600 ml Bottle Assembly
PART NO. 01-90-2454

ILLUSTRATION NO. 5